



Made in Canada

Cold Formed Steel Structural Panels

simplify **CONSTRUCTION**
improve **PERFORMANCE**

PAVERDECK

Galvanized Steel Structural Panels

Evolutiondeck Inc.

(USA) 605 Ridge Street, Sault Ste Martie, MI 49783

(CANADA) 25 Industrial Court B, Sault Ste Marie, ON P6B5Z9

1-800-725-5228 • www.spxsteel.com • info@spxsteel.com



APPLICATION. PAVERDECK™ pre-engineered panels are suitable for residential and commercial load bearing deck and floor applications, in compliance with AISI S100/CSA S136 “North American Specification for the Design of Cold-Formed Steel Structural Members”.

CODE COMPLIANCE. Compliance with the following codes:

- 2015, 2012 International Building Code® (IBC)*
- 2010 National Building Code of Canada
- 2012 Ontario Building Code

The products and engineered design described in this report may also be considered to be in compliance with the “2015 and 2012 International Residential Code (IRC), based on compliance with the IBC and permissibility language in R301.1.3 of the IRC.

CERTIFICATION. Underwriters Laboratories Evaluation Report ER38320-01. Conformance to AISI S100 validated by Dr. Roger A. LaBoube, Ph.D., Department of Civil Engineering and director of the Wei-Wen Yu Center for Cold-Formed Steel Structures at the Missouri University of Science and Technology.

REFERENCES.

A653/A653M-98 Z275 (G90)– Steel Sheet, Zinc Coated
SAE J78 – Self-Drilling Tapping Screws

AISI S100-12 / CSA-S136, North American Specification for the Design of Cold-Formed Steel Structural Members

SSMA - Sheet Steel Manufacturers Association (USA)

CSSBI - Canadian Sheet Steel Building Institute (Canada)

DELIVERY, STORAGE, AND HANDLING. Product may be stored outside, but protect and store cold-formed steel framing from corrosion, moisture staining, deformation, and other damage during delivery, storage, and handling as required in AISI’s “Code of Standard Practice”.

STANDARD SPECIFICATION. The Paverdeck product is manufactured to a single geometric configuration in lengths of 8, 10, 12, or 14 ft. The standard deck joist height is 6.25 inches and minimum uncoated thickness is 0.054in. System components are made from galvanized sheet steel as per ASTM A653/A653M-98 Z275 (G90), with a minimum yield strength of 50 ksi.

STRUCTURAL COMPONENTS.

- **STARTER CHANNEL:** Galvanized Steel SSMA/CSSBI 600S162-054.
- **PAVERDECK PANEL:** SPXZ/C 625S1200-054. Integrated joist diaphragm panels manufactured by Evolutiondeck Inc. with 6.25 inch joist depth, web-to-web spacing from 10-12 inches, and 0.054 in material thickness. Lengths from 8, 10, 12, 14 ft. Designed as field panels (SPXZ) and end-panel (SPXC).
- **BEAMS/LEDGER.** SSMA/CSSBI 1000S300-97 galvanized CFS steel, or equiv. (to max clear span < 10ft, based on loading), with SSMA/CSSBI 600S152-54 web stiffener installed at footing locations. Alternative solutions include painted structural iron conforming to Grade 350 W steel in ASTM A6, or wood beams for exterior applications (with intermediate isolation membrane) to be sized by a qualified designer.

- **FOUNDATIONS.** Compatible foundations must comply with the regional code. Where permissible, deck may be installed on grade using 20x20” concrete pads. Frost footings include: (1) 10-inch diameter concrete columns on sized footing forms; (2) filled concrete block on concrete footing pads; (3) helical pile foundation systems. Soil capacity by others.

- **COUNTRY OF ORIGIN.** All steel components are manufactured from galvanized steel in Canada. Self drilling fasteners are manufactured in Taiwan.

- **TESTING.** Full-scale independent testing completed by Innovative Test Solutions (Newmarket, Ontario) per ISO/IEC 17025:2005 A2LA accreditation. Failure tested to 560 psf @ 8-ft clear span without collapse.

- **VARIATIONS FROM SPECIFICATION.** Any item not specifically addressed herein shall comply with the regional building code as applicable. Contact Evolutiondeck Inc. for specific loading criteria or considerations.

Table 1 – Field Panel Structural Properties

Panel Properties	SPXZ 600S1200-43		SPXZ 600S1200-54		SPXZ 600S1200-68	
Min. design thickness (in)	0.043		0.054		0.068	
Minimum Yield Strength (ksi)	50		50		50	
Area (in ²)	-		1.3		1.5	
I _{xx} (in ⁴)	-		6.0		7.3	
Z _{xx} (in ³)	-		4.7		4.6	
I _{yy} (in ⁴)	-		20.8		25.1	
Criteria	ASD	LSD	ASD	LSD	ASD	LSD
Axial Strength, P (kip/ft)	-	-	-	-	-	-
Out-of-Plane Strength, M _{xx} (kip-in/ft)	-	-	29.1	43.6	38.2	57.4
In-Plane Strength, M _{yy} (kip-in/ft)	-	-	45.5	68.3	64.2	96.2

Table 2 – End Panel Structural Properties

Panel Properties	SPXC 600S1200-43		SPXC 600S1200-54		SPXC 600S1200-68	
Min. design thickness (in)	0.043		0.054		0.068	
Minimum Yield Strength (ksi)	50		50		50	
Area (in ²)	1.2		1.4		1.7	
I _{xx} (in ⁴)	5.2		6.3		7.7	
Z _{xx} (in ³)	4.8		4.7		4.6	
I _{yy} (in ⁴)	15.8		19.1		23.3	
Criteria	ASD	LSD	ASD	LSD	ASD	LSD
Axial Strength, P (kip/ft)	13.9	20.8	19.5	29.2	26.9	40.4
Out-of-Plane Strength, M _{xx} (kip-in/ft)	25.6	38.5	33.6	50.4	42.1	63.1
In-Plane Strength, M _{yy} (kip-in/ft)	29.8	44.7	42.3	63.5	59.8	89.7

Notes on Tables 1 and 2:

1. Per AISI S100 / CSA S136 Section A1.2: ASD values based on a factor of safety, Ω = 2.0; LSD values based on a resistance factor of φ = 0.75.
2. Structural properties are based on minimum member dimensions shown in Figures 2 and 3.

Table 3 – Maximum total (factored) uniform load for floor, roof, deck (psf)

Span Length	Field (Z-profile) panel					
	SPXZ 600S1200-43		SPXZ 600S1200-54		SPXZ 600S1200-68	
8 ft	-	-	303	454	398	598
10 ft	-	-	194	291	255	383
12 ft	-	-	135	202	177	266
14 ft	-	-	99	148	130	195
16 ft	-	-	76	114	99	149
Span Length	End (C-profile) panel					
	SPXC 600S1200-43		SPXC 600S1200-54		SPXC 600S1200-68	
8 ft	267	401	350	525	439	657
10 ft	171	257	224	336	281	421
12 ft	119	178	156	233	195	292
14 ft	87	131	114	171	143	215
16 ft	67	100	88	131	110	164

VIBRATION. Vibration serviceability design > 11 Hz, calculated as $F = 18/\sqrt{\Delta}$, where Δ = midspan deflection based on live loading.

DEAD LOAD. PAVERDECK™ steel system has a dead load of 5 psf, excluding the surface finish.

MAX. CLEAR SPAN BETWEEN BEAMS. 12-ft based on min. L/360 service deflection (Residential), 10-ft otherwise.

MAX. CANTILEVER. 39in. based on L/360 service deflection.

CONCENTRATED LOADS. 1045 lbs over an area of 30in x 30in. Larger concentrated loads can be achieved by inserting stiffeners under the point load. See www.paverdeck.com for more information.

GUARD POSTS. Guard post (not exceeding 42-in. high) to be installed max. 54 inches apart and through-bolted through surface finish to steel deck using 4 @ 5/16" x L diam. bolts per ASTM A307 or better, with a 8"x9" steel stiffener bolted beneath per assembly instructions. Field assembly of railing or guard to be completed according to manufacturer instructions.

CUTTING. Panels may be cut in the field. Additional corrosion protection is not required on edges of metallic-coated steel framing members, shop or field cut, punched or drilled.

INLINE FRAMING. Distributed or concentrated loads from a roof column, rafter, truss, and/or structural stud requires a stiffener (fabricated from SSMA/CSSBI 1000S300-097 steel channel, built-up laminated lumber or equiv.) in the joist space beneath the point load aligned vertically over a footing. Cumulative point loads from roof columns etc. are to be aligned vertically with a suitable foundation support beneath.

LATERAL BRACING. Check with local officials for specific lateral conditions. Ensure adequate stability of the structure as a whole and adequate lateral, torsional and local stability of all structural parts. Lateral bracing may be achieved: (a) installing a 1/2" diam. x 6 in lag screw max. 24 inches on centre through steel bracket attached to the joist web into rim joist or header of home; (b) installing a min. 24" steel channel (min. 1"x1" x 14ga or equiv.) from the beam to a joist web using M12x1 self drilling fasteners, or equiv.

SURFACE FINISHES. See paverdeck.com for surface finish installation. Compatible surface finishes include:

- stone or concrete pavers (0.75 to 4 in. thick)
- cast concrete (to 4 in.)
- porcelain tile, natural stone tile rated for exterior use
- composite or plastic decking (subject to manufacturer's warranty)
- natural wood decking.

FASTENER CONNECTIONS. PAVERDECK™ systems are assembled using all-weather M12 x 1 self-drilling screws as described in ESR – Report 1976 (Tek), ER-4780 (Dril-Flex), ER-5454 (Pro-twist), ER-5280 (Grabber) or equivalent. Fasteners into beams may be powder-actuated mechanical fasteners with ballistic points and electroplated zinc coating conforming to ASTM B 633, SC 1, Type III. Typical Hilti X-U-19 P8. Note fasteners are manufactured in Taiwan.

FIGURE 1 - ASSEMBLY

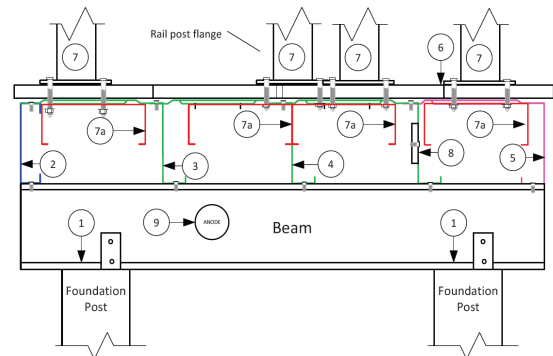

ASSEMBLY (SEE FIGURE 1).

1. At least one fastener will be located at all intersections between the structural beam, deck panels, and the starter C-channel. Install the beam onto the foundation columns using standard brackets and fasteners. Install a web stiffener at the beam location above the footing.
2. Install the STARTER C-Channel over top of the BEAMS using the supplied screw fasteners or powder actuated fasteners.
3. Then install first INFIELD deck panel, seating the leading right edge of the section on top of the previously installed STARTER. Secure this joint using the approved screws not more than 3.0 inches from either end and 12.0 inches between screws. Secure the bottom flange onto the structural beam using at least one fastener.
4. Continue adding and securing the INFIELD panels in a similar manner along the width of the structure to the desired width. Panels can be spaced from 10-11.0 inches apart. A panel may be ripped along the diaphragm to a custom width.
5. Install an End Panel section as the last piece along the width of the deck. This panel may be ripped lengthwise through for fitting. Fascia cap is non-structural and can be installed to over open joist space to support finish fascia material.
6. Surface finishes may be applied using known techniques suitable to the finish employed. See www.paverdeck.com.
7. Locate guard post base flange min. 1" from edge of metal deck, and install 4 bolts through clearance hole in surface finish and through steel deckpan, using min. 5/16" diam. x 3.5" Gr. 2 galvanized steel bolts per ASTM A307 or better. Insert galvanized washers between bolts and base flange and nuts and metal deck, with 8"x9" deck stiffener in joist space beneath the post. Stiffener may be selected from min. SSMA/CSSBI 800S250-097 galvanized steel channel (available from Evolutiondeck Inc.), 8"x9"x3/16" steel plate, (7a). Orient the stiffener such that 9-inch flanges are perpendicular to edge of deck supporting the guard post (see figure 1-B for various post configurations).
8. Install optional zinc anode system (R3 type zinc anode) bolted through the joist web at a location accessible in the future to inspect and replace the anode.
9. The beams and platform may be installed below grade, with zinc anode system bolted through the joist web at a location accessible in the future to inspect and replace the anode.

FIGURE 1-B GUARD POST CONFIGURATIONS

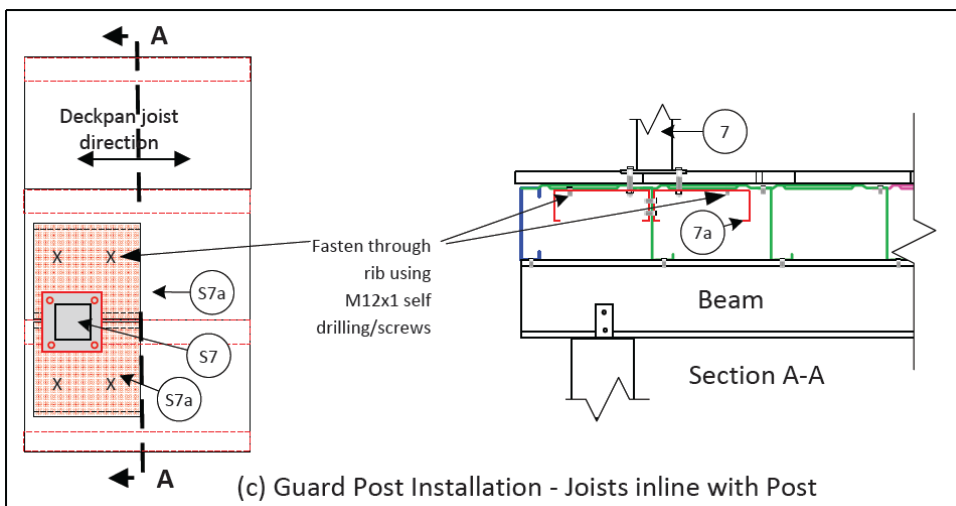
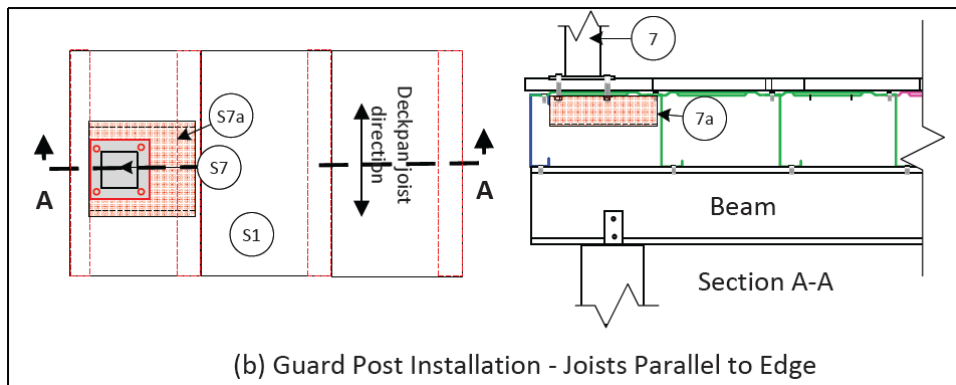
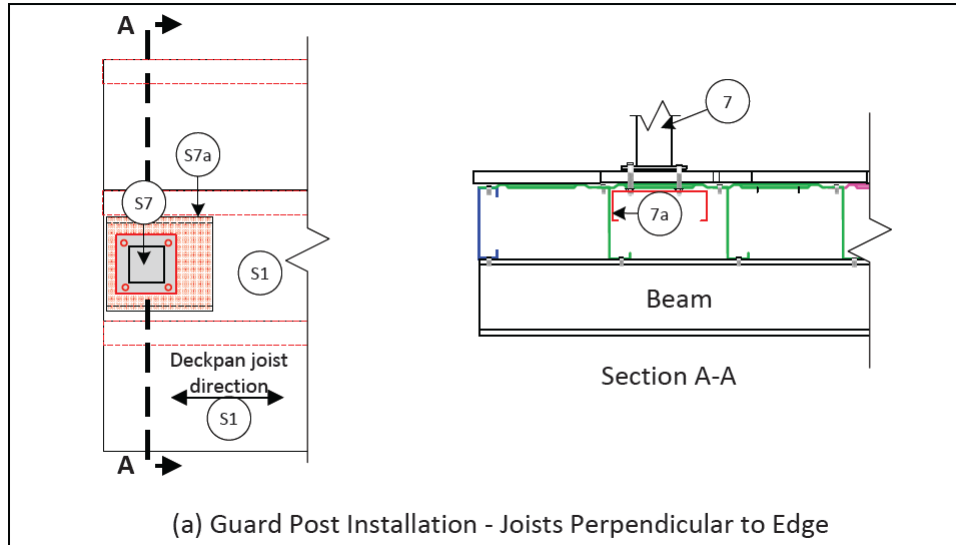

PAVERDECK™

Evolutiondeck Inc., 25 Industrial Court B, Sault Ste Marie, ON
 1-800-725-5228 • mail@paverdeck.com

EDECK625-S1200-54

Specification, Page 5

Rev. 2018-03-17

ASSEMBLY SEQUENCE.

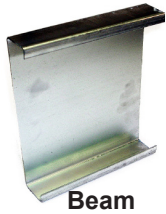

Beam

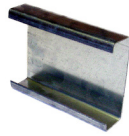

Starter Channel

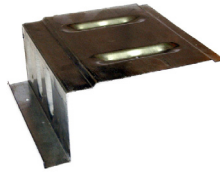

Field Panel



End Panel

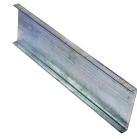

Fascia Cap



1

Frost footings or floating pads.



6

Glue perimeter stone to steel.
Heavy landscape fabric in field.

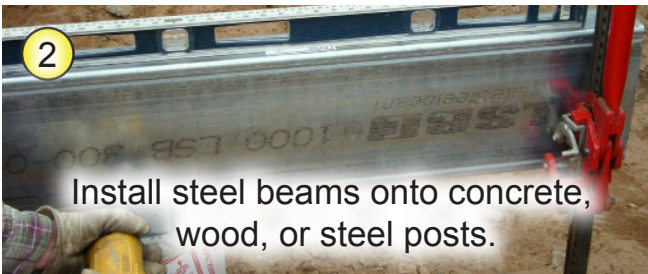

2

Install steel beams onto concrete,
wood, or steel posts.



7

Dry lay field pavers over fabric.



3

Screw starter channel and field panels.



8

Lock in pavers with polymeric sand.

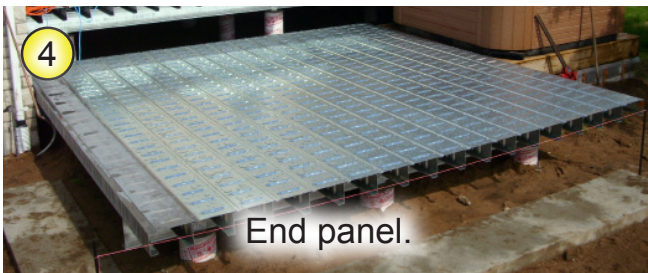

4

End panel.



9

Wet cure polymeric sand.



5

Fascia cap.

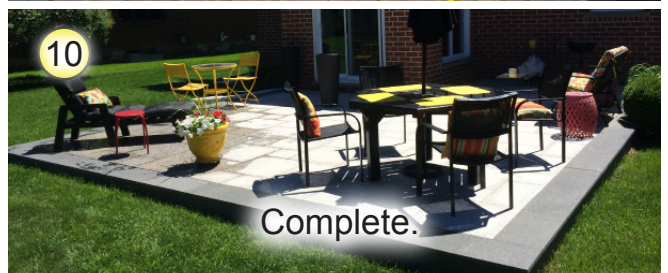

10

Complete.

See complete details at www.paverdeck.com.

STAIR SPECIFICATION.

COMPONENTS. The EDECK™ stair system is comprised of the following principal components, made from galvanized sheet steel manufactured in compliance with ASTM A653/A653M-98 Z275 (G90), and minimum yield strength of 50ksi.

Stringers. Compatible stringer designs to be galvanized cold formed steel stringers conforming to SSMA / CSSBI or CSSBI as follows; (a) 600S162-054 for maximum 5 treads per flight at 72-inch wide tread; (b) 800S162-054 for maximum 13 treads per flight at 72-inch wide tread.

STAIR HANGAR CHANNEL. Galvanized cold-formed steel c-channel in accordance with CSSBI/SSMA / CSSBI 600S162-054, or equiv.

INFIELD STAIR PANEL (EDECK 725-S1100-054). Integrated field stair panels manufactured by Evolutiondeck Inc. with 7.25 inch riser height and 11-inch treqd depth.

FINISH STAIR PANEL (EDECK-625S1100-054). Integrated end stair panels manufactured by Evolutiondeck Inc. with a 6.25 inch riser height.

SURFACE FINISHES. Suitable finishes are adhered to stair panels using polyurethane glue (per ASTM D3498 and AFG01). Finishes include pre-cast concrete pavers; natural stone pavers; cast-in-place concrete; recycled rubber pavers, PVC decking etc.

SUBGRADE PREPARATION. For floating staire platform, provide compacted aggregate footing base (per ASTM D 698) for pedestrian areas.

COLUMNS AND FOUNDATIONS. Note Evolutiondeck Inc. makes no representations or designs regarding the loading capacity of the footing, as footing design is dependent on local soil bearing conditions - check with local building officials for minimum sizes. Foundation pads or grade beams are placed on compacted subgrade base optionally below the frost line as required by the building code. Compatible foundations include: (1) 254 mm (10-inch) diameter concrete columns on expanded footing forms (e.g. Bigfoot); (2) helical pile foundation systems (installed per manufacturer specifications); and (3) 4"x 4"x 0.1875" HSS steel column with adapters for securing to concrete footing pad and beam attachment; or equiv.

ANODE CORROSION PROTECTION. While the EDECK™ system has a long service life, it is optional to provide a R3 disc-type zinc anode (per ASTM B-418-95 Type II, MIL-18001 or equiv.) for stair system bolted to joists at location(s) to facilitate inspection every five years.

MAXIMUM CLEAR SPANS. (a) Stair tread maximum clear span between stringer supports = 48 inches; (b) stair tread maximum cantilever = 12 inches.

MAXIMUM UNIFORM LOADS. The EDECK™ stair system remains elastic and satisfies structural performance requirements for uniform live load combinations or a 300 pound concentrated load acting over an area of 4 square inches at the 48in clear span. Maximum paver or other surface finish loading may not exceed

VARIATIONS FROM SPECIFICATION. Any item not specifically addressed herein shall comply with the applicable building code.

FASTENER CONNECTIONS. EDECK systems are assembled using all-weather M12 x 1 self-drilling screws as described in ESR – Report 1976 (Tek), ER-4780 (Dril-Flex), ER-5454 (Pro-twist), ER-5280 (Grabber) or equivalent. Connections of stringer to hanger are further reinforced using 2 @ 1/4" diameter galvanized or stainless steel bolts.

STAIR INSTALLATION.

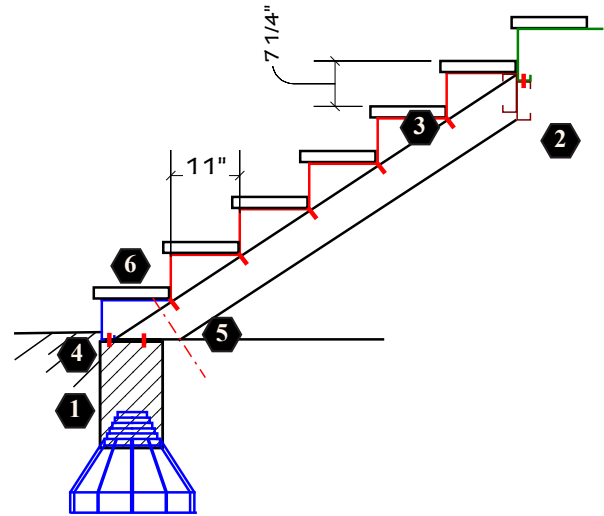

1. At least one screw fastener will be located at all intersections between the stair tread and stringer, EDECK stair panels, and the hanger. Install the stringer onto the foundation columns or pad, using suitable bracket and fasteners.
2. Install the hangers to the deck system using the supplied screw fasteners. Reinforce with two (1) 1/4" diameter galvanized steel bolts at each end of hanger.
3. Then install first INFIELD EDECK in-field tread section, seating the leading edge of the section on top of the previously installed HANGER. Secure this joint using the approved screws not more than 3.0 inches from either end and 6.0 inches between screws. Secure the EDECK bottom flange onto the STRINGER using one screws on each side. Continue adding and securing the INFIELD EDECK stair tread sections in a similar manner along the length of the STRINGER.
4. Install the FINISH stair panel to your finished grade elevation and fastening to the stringer bracket. Secure this tread to the preceding INFIELD tread section using the approved screws not more than 3.0 inches from either end and 6.0 inches between screws. Secure the FINISH panel bottom flange onto the foundation column/slab using appropriate Tapcon or equivalent screws. The FINISH panel may be cut to accommodate grade restrictions. Cut edge to be reinforced with brackets (or equiv.) every 6-inches along the length.
5. Install optional zinc anode system bolt through the joist web at a location accessible in the future to inspect and replace the anode.
6. Surface finishes may be applied using polyurethane adhesive (typical Miracle Lumberlock) using known techniques suitable to the finish employed.